

Product Data Sheet 16 SERIES



web: <https://stairnosingaustralia.com.au/>

Contact : Daphne 0422 803 365

email: daphne@stairnosingaustralia.com.au

STAIRNOSING 16 series-stair nosing suitable for carpet tile and vinyl plank

This stair nosing is ideally suited to be installed on steps that have carpet tiles installed on them.

This stair nosing has a 10 mm face or riser, fulfilling all requirements of the AS1428 2009 BCA standards.

The greatest benefit is the generous space it gives you when installing carpet tiles on the riser of the step. It is very easy when the rebate is a generous 35 mm.

SPECIFICATIONS

PRODUCT	16 Series
BASE MATERIAL	Alloy: 6060, Temper: T5
FINISH	Clear [silver] Black & Sovereign Gold Anodised – 25Um
TREAD WIDTH	75mm
FRONT DEPTH	10mm
TREAD THICKNESS	6mm
INSERT TYPE	Carborundum - Epoxy - Santoprene rubber PVC-Mineral PVC-aluminium ripple trim
PRODUCT WARRANTY	2 Years (As per Stair Nosing Perth's standard warranty conditions) 5 Years (if installed by Stair Nosing Australia)
INSERT SLIP RATING	P4 classification for PVC and P5 classification (Highest available)
CODE COMPLIANCE	AS1428.1-2009 Check floor finish colour for luminance contrast requirements and LRV [Light Reflective Values] Screw fixed/or adhesive
FIXING METHOD	Screw fixed
APPLICATION	Profile installed prior to carpet tiles. Holds carpet tiles on tread and riser.

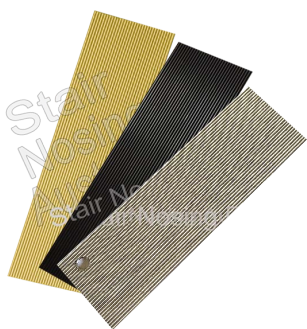
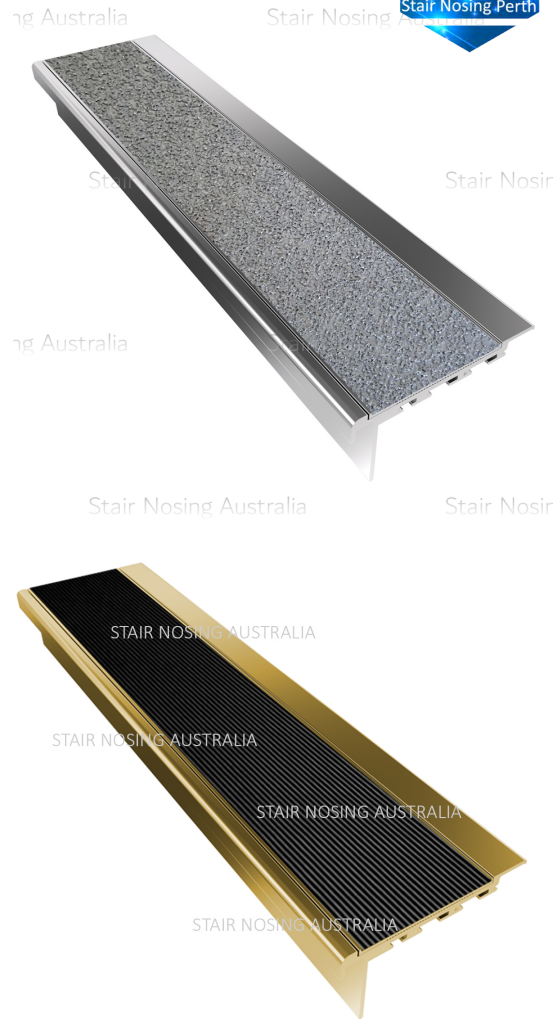
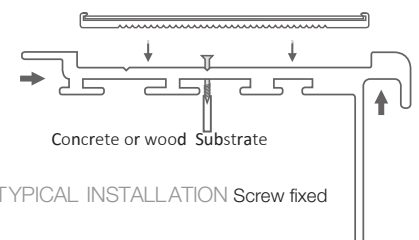
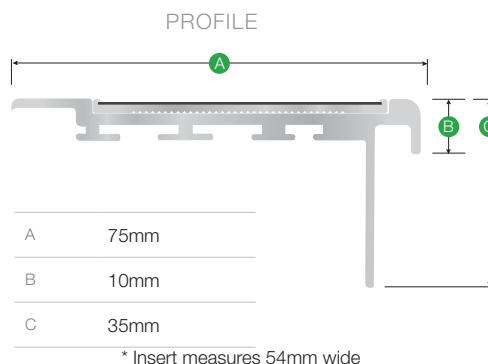

716 Anodised ripple trim



416 Carborundum



116 Epoxy carbide



316 Santoprene Rubber